



*Blackstone TEK*

**BEARING REPLACEMENT  
PROCEDURE**

The procedure will be shown in step-by-step form with images.

## **Method**

Step 1: Remove both the Brake spacer and Inner Sprocket Spacer, as shown in the images.

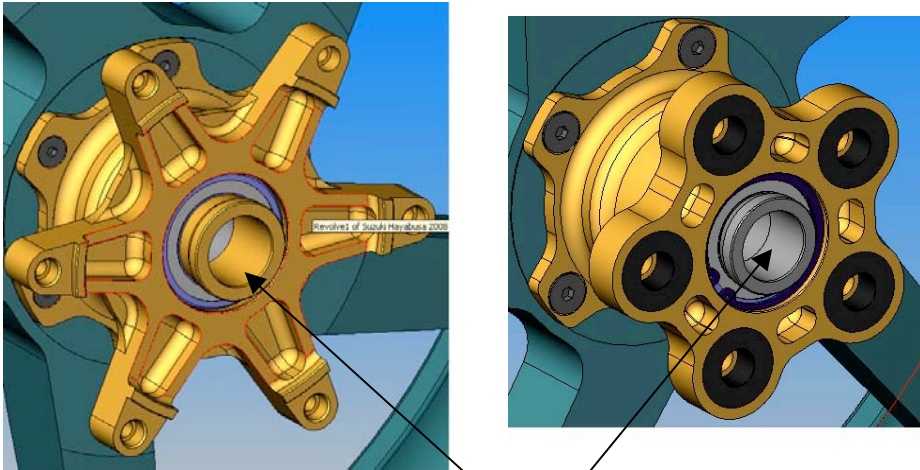

Spaces

Step 2: Remove the circlip from the Drive adaptor.

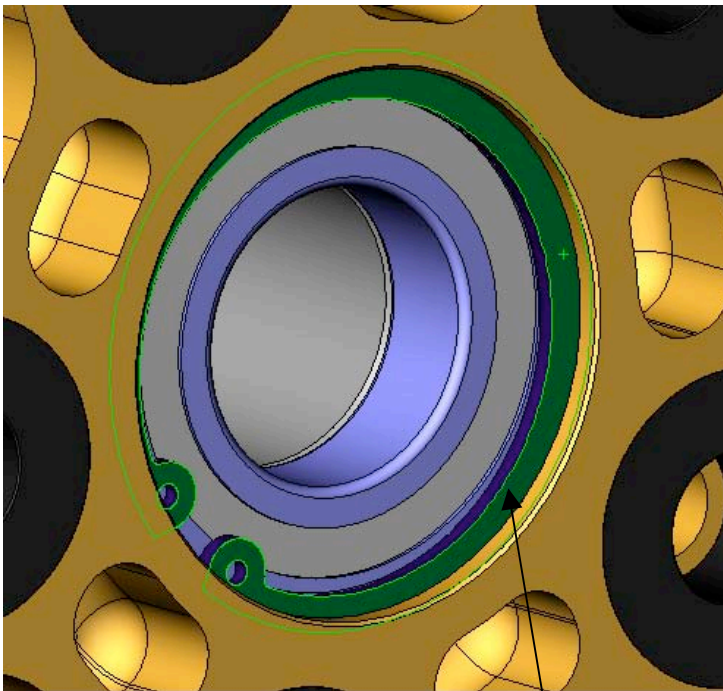

Circlip

Step 3: Push the inner spacer so that it is offset from the bearings. The first bearing to be removed will be from the brake adaptor. Place the wheel with the **FACE** of the brake adaptor resting on the press apparatus. Using a rod, evenly press the bearing out of the brake adaptor. Make sure that the bearing will not touch the press apparatus while being removed.

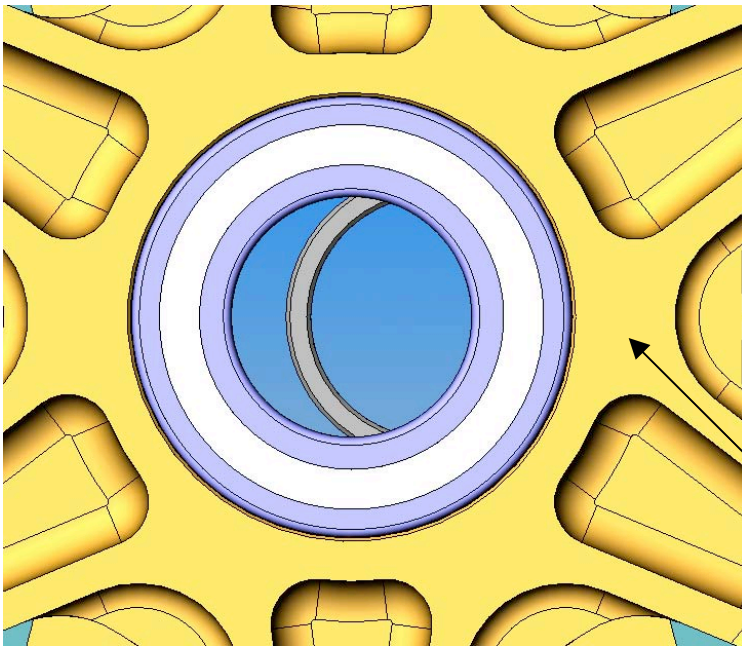

**FACE**

Step 4: Place the wheel with the **FACE** of the drive adaptor resting on the press apparatus. Using a shaft or pipe, smaller than the bearing seat diameter, press the bearing out of the drive adaptor.

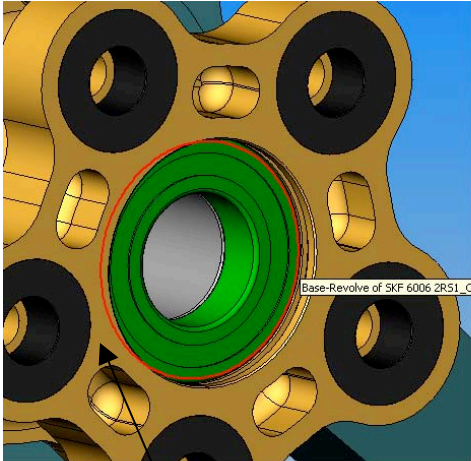

**FACE**

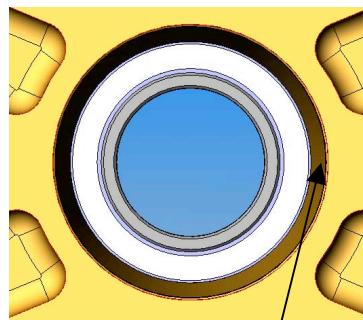

**Bearing seat diameter**

Step 5: The first bearing to be replaced is the drive adaptor bearing. Position the bearing in place. Lightly tap the bearing with a rubber hammer to make sure that it will be pressed in straight. Place the wheel on the press apparatus on the same face as in Step3. Press the bearing into the adaptor using a flat round washer that is smaller in diameter than the bearing, for clearance from the adaptor, until the bearing is seated.

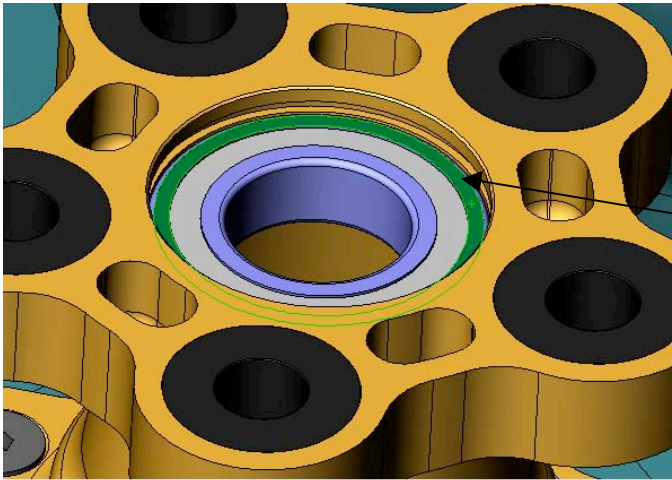

Press on  
the outer  
race of the  
bearing

Step 6: Turn the wheel around, replace the inner spacer on the **Inner Race** of the drive adaptor bearing.

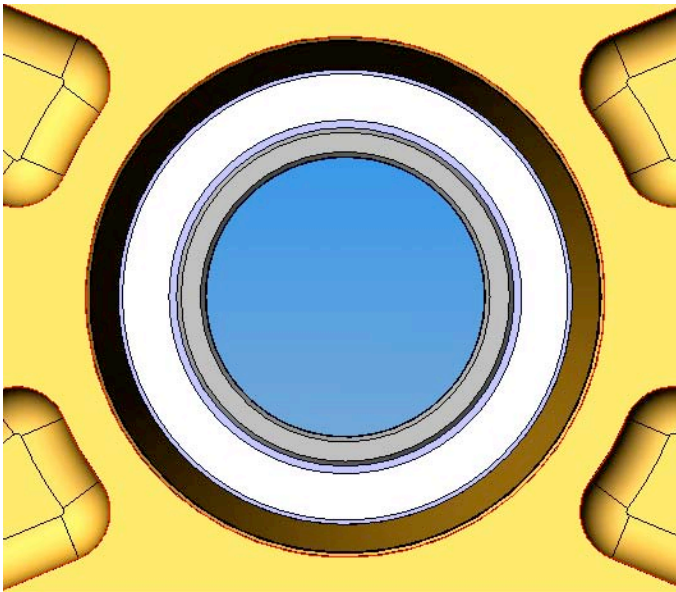

Step 7: The same procedure that was done in step 5 will be done on the brake adaptor bearing. The only difference is the wheel must be supported on the washer used to press in the drive adaptor bearing and that the bearing must bottom onto the inner spacer.

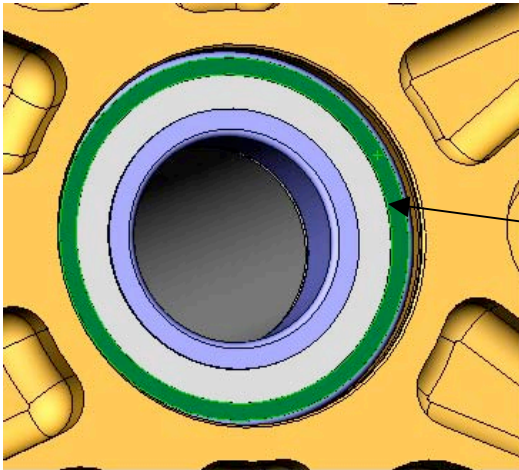

Press on  
the outer  
race of the  
bearing

Step 8: Reposition the circlip into the cush adaptor.

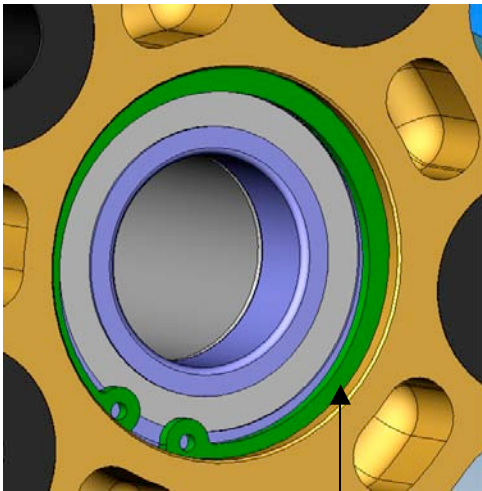

Circlip

Step 9: Reposition the brake spacer and the inner sprocket spacer into the correct bearings.

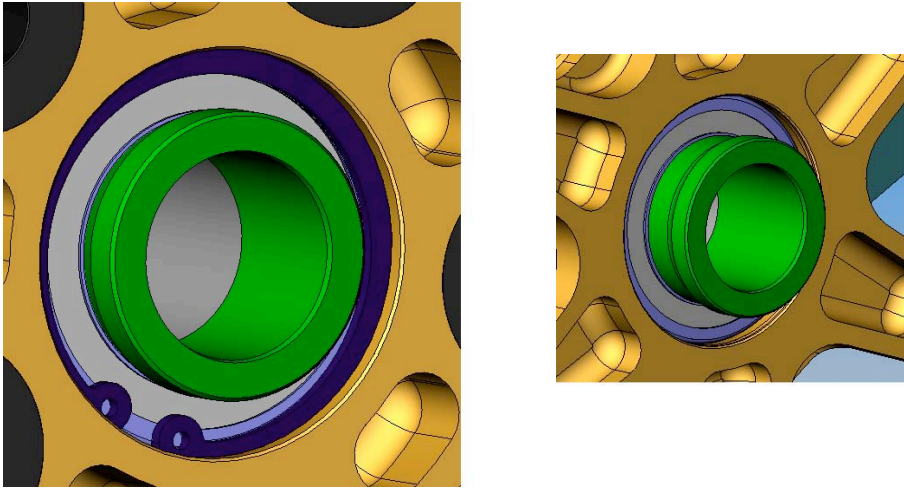

Step 10: After refitting the wheel to the bike and after the wheel axel has been torqued, the distance between the drive adaptor and the sprocket carrier must be measured. The distance must be  $0.8 \text{ mm} \pm 0.2 \text{ mm}$ .

