



Brock's Performance Products • 4064 East Patterson Road • Dayton, OH 45430 • Phone: 937-912-0054 • Fax: 937-912-0062

## Installation instructions for Suzuki GSX-R1000 (2007-08) Exhaust Systems

The Generation 3 StreetSmart/ Alien Head/ Short Meg/ Street Meg Exhaust Systems for the 2007-08 GSXR 1000 are high performance 4-2-1 exhausts which replace the stock headers, mid-pipes, and mufflers. It converts the stock dual-muffler design into a single-sided muffler mounted on the right side of the bike.

### CHECK PACKAGE CONTENTS

1. Four (4) Header Mount Flanges (Installed in Headers)
2. One (1) Left Side Header (Cylinders 1 & 2 Primary)
3. One (1) Right Side Header (Cylinder 3 & 4 Primary)
4. One (1) Collector (Y-Pipe)
5. One (1) Mid-Pipe (Elbow)
6. One (1) Muffler (Optional Alien Head Muffler Shown)
7. One (1) Package Containing Springs, Spring Puller, Bracket and Hardware
8. One Black Rubber Cap (Not Shown)
9. One (1) Instruction Package



If any parts are missing, contact Brock's Performance Products.

### **Brock's Performance Alien Head System**

### PRE-ASSEMBLE HEADERS, COLLECTOR, AND MID-PIPE TO ENSURE PROBER FIT BETWEEN ALL PARTS

Brock's Performance carefully inspects each system prior to shipping, we recommend that you test fit your system prior to installation. Apply WD-40 to the joints to ease assembly, adjustment, and/or disassembly.



### REMOVE BODYWORK

Remove body work by removing the fasteners. Start with all of the Allen Head bolts, then the plastic fasteners on the front and bottom of bike (behind the front tire). The bodywork is held on by a couple of rubber grommets so the body work may not "fall off" like previous years. Start at the bottom and work your way up. After the bottom is loose, you may need to lift up on the bottom almost like a "wing" to remove the top. Be very careful not to break any tabs off while doing this. Once either side is off continue in the same fashion to the other side. There is no need to take off the guard for the oil cooler, it will stay in place.

### REMOVE THE MUFFLERS

When removing the mufflers always start at the fastener closest to the front of the bike. The bolt only needs to be loosened not removed. Move up the muffler to the passenger peg bolt that secures the back of the muffler. Completely remove the bolt holding the muffler bracket but be careful not to let the muffler drop on the ground when doing this.

You may need to apply a little twisting force when removing the muffler. Then proceed to the other side of the bike and repeat these last steps.

### REMOVE THE CATALYTIC CONVERTER

As you move forward from where the mufflers were connected to the front part of the exhaust system you will notice there is a flat black object that looks like a box...that is the catalytic converter ("cat"). Unplug the stock O<sub>2</sub> sensor from the connection on the left side of the oil pan. Loosen the front of the cat from the head pipes, do not remove the bolt only loosen. Remove the mounting bolt behind the connection of the right muffler and the cat, but be careful not to drop the cat on the ground when doing so. Remove the cat.

### REMOVE THE HEAD PIPES

Start by removing the cables from the exhaust control valve. Unscrew the bolts at the valve until you can gently pull them out and direct the cables around the wheel so you are able to "pop" out the ends out of the wheel. Let the cables hang on the ground. You will no longer need these. Remove the bolt from the lower radiator and oil cooler mounting bracket to allow you to push these two forward to make room for the removal of the headers. Remove all eight (8) of the Allen Head bolts holding the four primaries to the head. Be careful not to hit the flanges of the pipes on the radiator, some times a piece of cardboard will help in this area for protection of the radiator. Check to make sure the exhaust gaskets are still in the head, you will reuse these.

### INSTALL FLANGES

Remove the flanges from the headers. Using the eight (8) Allen head bolts from the original flanges, attach the flanges with the larger flared side against the gaskets in the cylinder head and aligned as shown. Make sure flanges are flat to the gaskets and tighten flanges to 10-15 ft-lbs to promote a proper seal.

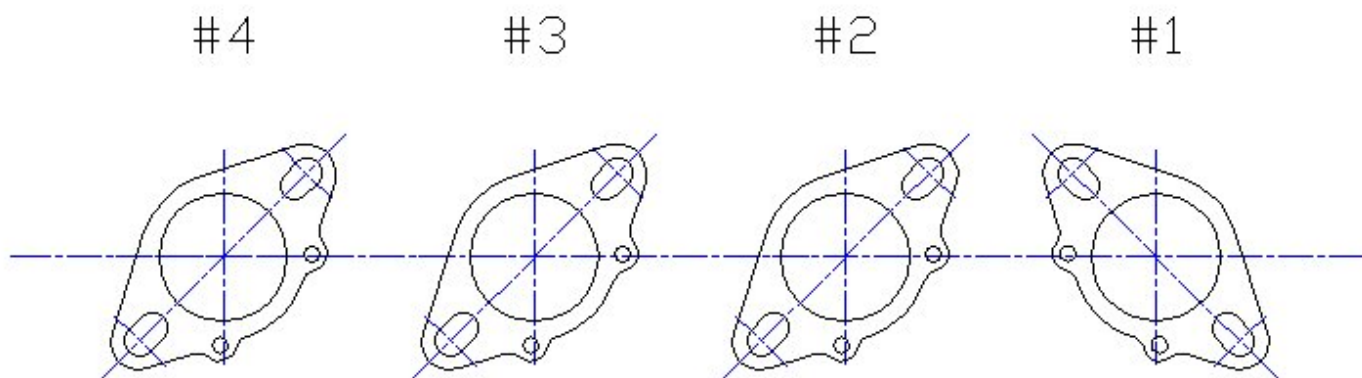

### INSTALL HEADER PIPES

Apply a small amount of Permatex Ultra Copper to inside of the header pipes. Install the header pipes onto the flanges while making sure not to hit the radiator and oil cooler. After one side of the primaries are installed, attach the two (2) springs to the tabs on the head pipes. Then repeat to the other side. Re-install the lower radiator / oil cooler mounting bracket bolt. Check to make sure the radiator as well as other hoses have clearance from the head pipes.



### INSTALL COLLECTOR AND MID-PIPE

Install the collector (Y-Pipe) to the head pipes with two supplied springs. Once the springs are on, give the collector a good wiggle so it can seat against the head pipes. Install the mid-pipe (elbow) with two supplied springs as well.

## INSTALL BRACKET AND/OR MUFFLER

*Alien Head and Short Meg systems:* Remove the two (2) bolts securing the right foot peg to the frame and replace bolts with supplied longer bolts. From the inside, place the bracket over the bolts with shiny side facing out and install the supplied washers and locking nuts. Install the Alien Head or Short Meg muffler by using the supplied bolt, washers, nut, and springs.

*Street Meg and 20" Alien Head Street Meg:* Install the muffler with the supplied springs. Install the hanger bracket to the stock mount on the passenger foot peg using the original stock muffler bolt. Attach the Alien Head or Street Meg muffler to the bracket using the supplied bolt, washers, and nut.

*Gen 3 system:* Install the muffler with the two (2) supplied springs. Peel off protective coating on muffler hanger and attach rubber to the muffler hanger. Install hanger around muffler and attach to the stock mount on the passenger foot peg using the original stock muffler bolt.

Re-check all fasteners of system to make sure everything is tightened properly.

## CLEAN SYSTEM OF FINGER PRINTS

With any exhaust system you must clean all finger prints off before starting the motorcycle to insure there will not be finger prints "burned" into the pipe. Carefully use alcohol, brake clean, etc. to clean the system.

## INSTALL BODYWORK AND CHECK CLEARANCE

Replace all bodywork in reverse order of removal. *Bodywork must be at least 1/4 of an inch from any part of the exhaust system.* Minor adjusting of exhaust system may be necessary for adequate clearances. Brock's Performance does not warrant burned plastic bodywork.

## ADDITIONAL

Review documents for PAIR valve and FI light modifications.  
Install the appropriate Power Commander map for your application.

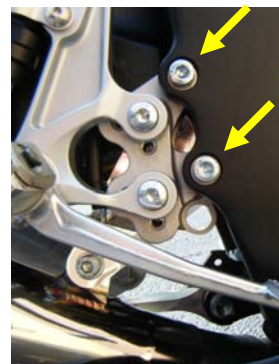

**Brock's Performance Products are designed for Closed-Course Racetrack use ONLY**

For more information go to [www.BrocksPerformance.com](http://www.BrocksPerformance.com), **click:** Installation Instructions

**email:** [Advice@BrocksPerformance.com](mailto:Advice@BrocksPerformance.com), or call: 937-912-0054

**Brock's Performance Products policies and warranty information:** [www.BrocksPerformance.com](http://www.BrocksPerformance.com), **click:** Policies



4064 East Patterson Road  
Dayton, OH 45430  
Phone: 937-912-0054  
Fax: 937-912-0062

### Installation instructions for Suzuki GSX-R1000 (2007-08) PAIR block-off cap

The pair block off cap is used to block off emissions (PAIR) to help prevent 'deceleration pop' and also prevents ram-air pressure loss from the airbox after blocking the PAIR.

1. Lift and prop gas tank.
2. Remove PAIR hose from air box port located on front right of air box (while seated on bike.) See figure 1.



Fig. 1.

3. Place the cap on port of air box as shown in figure 2.



Fig. 2.

4. Re-install PAIR hose over the cap and port as shown in figure 3. (Note: WD-40 may be helpful for installation.)



Fig. 3.

5. Lower tank.

**Brock's Performance Products are designed for Closed-Course Racetrack use ONLY**

For more information go to [www.BrocksPerformance.com](http://www.BrocksPerformance.com), **click:** Installation Instructions

email: [Advice@BrocksPerformance.com](mailto:Advice@BrocksPerformance.com), or call: 937-912-0054

Brock's Performance Products policies and warranty information: [www.BrocksPerformance.com](http://www.BrocksPerformance.com), **click:** Policies





4064 East Patterson Road  
Dayton, OH 45430  
Phone: 937-912-0054  
Fax: 937-912-0062

### Suzuki GSX-R1000 (2007-08): Check F.I. Light Disconnect Instructions

When installing any Brock's Performance Products Exhaust System on the 2007-08 GSX-R1000, the following procedure must be followed to prevent illumination of the check F.I. Light.

Note: there is no need to use the "bowtie" plate provided with your system if you perform this modification to the wiring harness.

1. Disconnect the cables from the factory exhaust control valve actuator (EXCVA) located under seat/gas tank on the right side of the bike. DO NOT unplug the EXCVA electrical connectors from the wiring harness. Do not remove the EXCVA unit.
2. Remove the OEM exhaust system, exhaust control valve and cables.
3. Install your Brock's Performance Exhaust System according to the supplied instructions.
4. Locate the Black wire with White tracer (with two green dots) on the right side ECM coupler. See Photo below.
5. Cut the wire approximately 1.5 inches back from the coupler and insulate both ends with electrical tape.

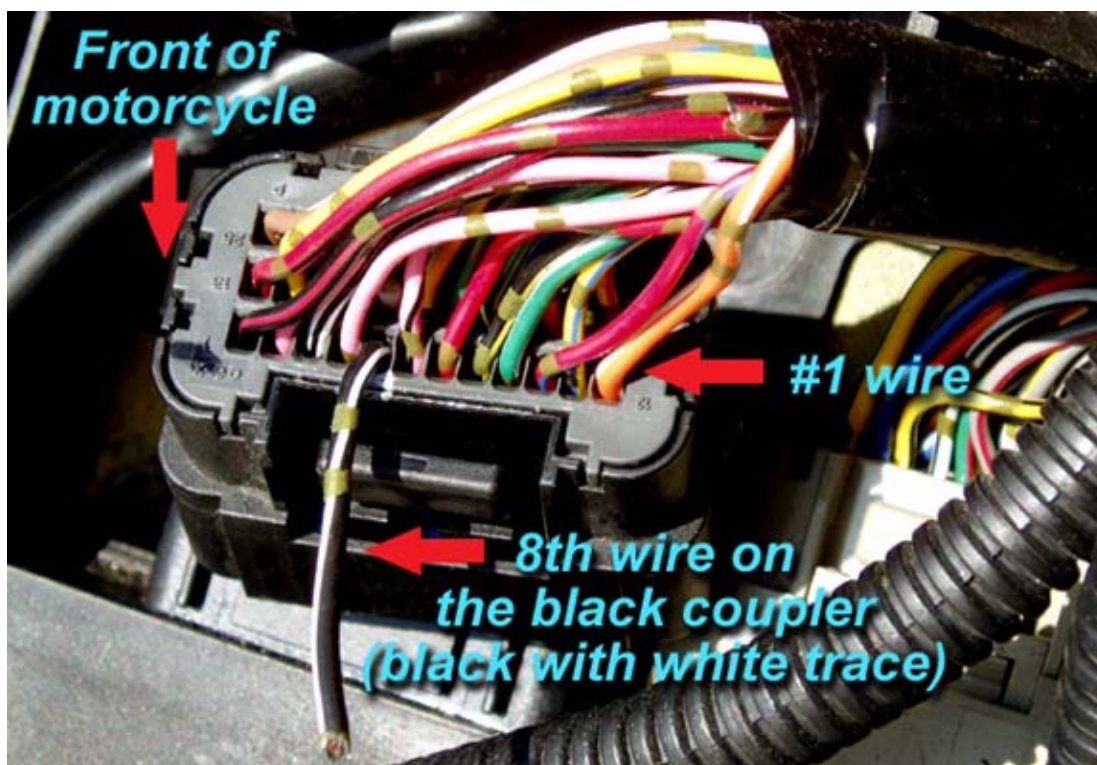

The motorcycle may now be operated in normal fashion without the check F.I. light illuminated.

Note: the "bow-tie" plate included with your exhaust system is NOT required if the above modification is performed.

**Brock's Performance Products are designed for Closed-Course Racetrack use ONLY**

For more information go to [www.BrocksPerformance.com](http://www.BrocksPerformance.com), **click:** Installation Instructions

email: [Advice@BrocksPerformance.com](mailto:Advice@BrocksPerformance.com), or call the: 937-912-0054

Brock's Performance Products policies and warranty information: [www.BrocksPerformance.com](http://www.BrocksPerformance.com), **click:** Policies